

# WC201060

V.5

## Aufbauanleitung

DE - Bevor Sie beginnen:

- Es ist empfehlenswert sich etwas Zeit zu nehmen, um die Aufbauanleitung zu lesen, bevor mit dem Aufbau begonnen wird.
- Der Aufbau sollte in der vorgegebenen Reihenfolge erfolgen.
- Die Aufbauanleitung dient lediglich als Richtschnur für den Aufbau. Nicht alle Schritte sind im Detail vorgegeben.
- Bitte prüfen Sie alle Teile auf Vollständigkeit und Zustand vor dem Aufbau. Der Aufbau sollte durch mindestens 2 Personen erfolgen.
- Bei starkem Wind sollte der Aufbau nicht erfolgen.
- Bohren Sie die Teile vor, wo es angezeigt wird.
- Wir empfehlen, das Gerätehaus erst nach weitgehendem Aufbau vor Anbringung der Deckleisten mit Farbe oder Holzlasur zu behandeln, da sich die Elemente bei einer einseitigen Behandlung verziehen können, wodurch der Aufbau erschwert werden könnte.

## Instructions d'assemblage

FR - Avant de commencer:

- Avant de commencer le processus d'assemblage, veuillez s'il vous plaît vous familiariser parfaitement avec les instructions.
- La maison doit être assemblée suivant la séquence indiquée dans les instructions.
- Les instructions s'entendent comme lignes directrices, toutes les étapes ne sont pas décrites en détails.
- Avant de commencer l'assemblage, vérifier tous les éléments.
- Deux personnes sont nécessaires au minimum pour l'assemblage.
- Ne pas tenter d'assembler la maison dans des conditions de vents forts.
- Percer les trous dans les éléments suivant les marques.

## Montage-instructie

NL - Alvorens te beginnen:

- Voordat u begint met de montage raden wij u aan de handleiding grondig door te lezen.
- Bij de montage van het huis dient u de volgorde zoals deze in de handleiding is aangegeven te volgen.
- De handleiding is bedoeld als richtsnoer, niet alle stappen zijn in detail uitgewerkt.
- Vóór de montage dienen alle details gecontroleerd te worden.
- De montage van het huis dient door tenminste twee personen uitgevoerd te worden.
- Het huis nooit in harde wind opbouwen.
- Gat en onderdelen boren, waar dit staat aangegeven.

## Pokyny k montáži

CZ - Než začnete:

- Než začnete s montáží, seznámte se důkladně s těmito pokyny.
- Domek musí být sestaven v pořadí uvedeném v pokynech.
- Pokyny slouží pouze jako vodítko, ne všechny kroky jsou zde popsány dopodrobna.
- Než začnete s montáží, zkontrolujte všechny díly.
- K montáži jsou zapotřebí minimálně dvě osoby.
- Nepokoušejte se smontovat domek za silného větru.
- Vyvrtejte do dílů otvory podle značek.

## Pokyny pre montáž

SK - Predtým, než začnete:

- Predtým, než začnete montovať, sa, prosím, dôkladne oboznámte s týmito pokynmi.
- Dom je potrebné zmontovať podľa poradia uvedeného v pokynoch.
- Tieto pokyny poskytujú návod, nepopisujú však detailne všetky kroky.
- Predtým, než začnete montovať, skontrolujte všetky časti.
- Pri montáži sú potrební najmenej dvaja ľudia.
- Nepokúšajte sa montovať dom pri silnom vetre.
- Otvory v jednotlivých častiach vyvrtajte podľa označenia.

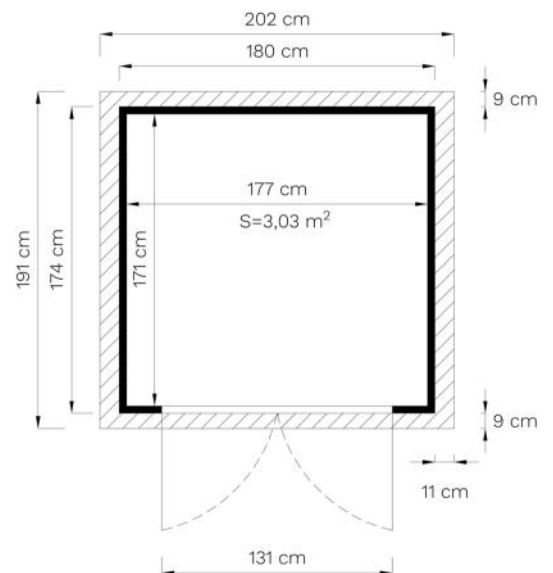
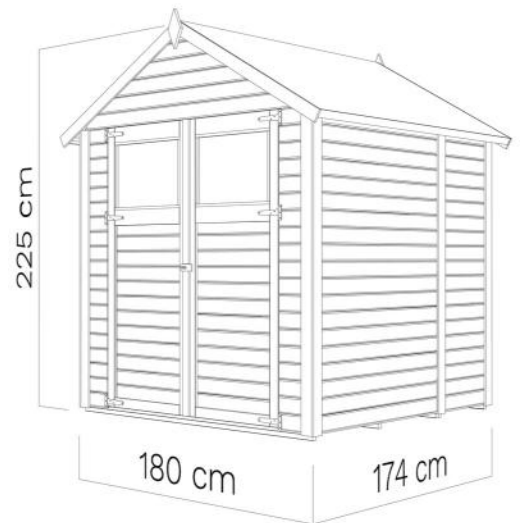

Fundamentplan / Foundation Plan

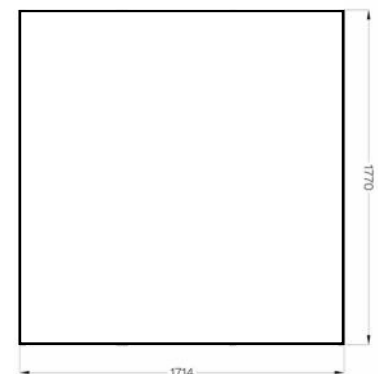











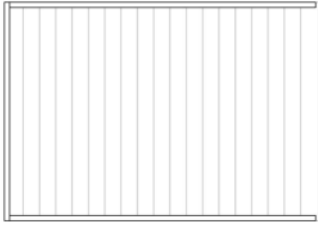

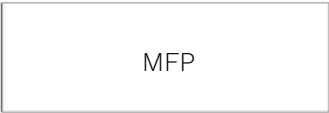



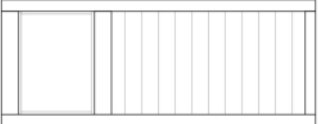
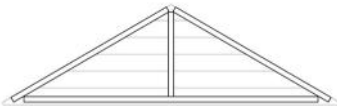



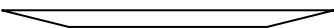

DE - Technische Änderungen vorbehalten.

Alle Maße sind ca. Maße.



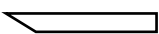









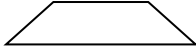

EN - Technical modifications reserved.

All dimensions are approximate dimensions.

# WC201060

ID	Details in mm (Tolerance/Toleranz ...+ 2mm)	Pcs.	ID	Details in mm (Tolerance/Toleranz ...+ 2mm)	Pcs.
				42 x 1174 x 1703	
			<b>231</b>		x 3
<b>232</b>	42 x 540 x 1703 	x 3	<b>919</b>	16 x 540 x 1770 	x 1
<b>315</b>	42 x 201 x 1703  	x 1	<b>314</b>	42 x 201 x 1703  	x 1
<b>317</b>	30 x 665 x 1655 	x 2	<b>316</b>	42 x 524 x 1770 	x 2
<b>516</b>	12 x 830 x 1150 	x 4	<b>679</b>	12 x 230 x 1150 	x 2
<b>536</b>	1 x 1000 x 2000 	x 2	<b>524</b>	1 x 500 x 2000 	x 1
<b>921</b>	28 x 28 x 1714 	x 4	<b>807</b>	28 x 28 x 1021  	x 8
<b>803</b>	28 x 28 x 945 	x 4	<b>822</b>	28 x 28 x 1312 	x 1
<b>792</b>	28 x 28 x 370 	x 2	<b>623</b>	12 x 70 x 1680 	x 11
<b>614</b>	12 x 70 x 1165  	x 4	<b>929</b>	12 x 42 x 807 	x 2
<b>590</b>	12 x 42 x 1680 	x 4	<b>628</b>	12 x 90 x 201 	x 2

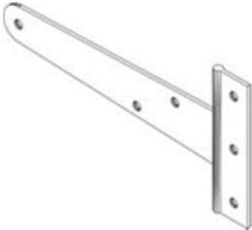
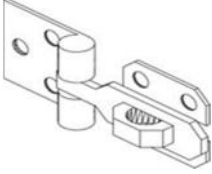
# WC201060

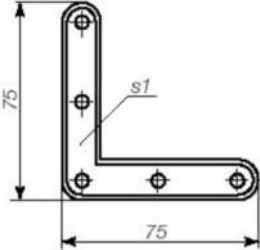
ID	Details in mm (Tolerance/Toleranz ...+ 2mm)	Pcs.	ID	Details in mm (Tolerance/Toleranz ...+ 2mm)	Pcs.
703	15 x 15 x 529 	x 4	1000	15 x 15 x 384 	x 4
630	12 x 90 x 450 	x 4	1552	3 x 540 x 395 	x 2
1505	Ø4,5 x 50 	x 78	1506	Ø3,5 x 35 	x177
1507	Ø3,5 x 30 	x 50	1508	Ø4 x 25 	x 8
1509	Ø3,5 x 19 	x 13	1512	Ø1,4 x 25 	x 28
1513	Ø3 x 10 	x134	1556		x 1
1516		x 6	1518		x 1
1517		x 2	1562	Ø3 x 25  	x20 x 4

**NB!** Empfohlen bei Aufbau auf besonders feuchtem Untergrund.  
Recommended for assembly on moist ground.

**\* Nicht im Lieferumfang enthalten / Not included!**

\* Unterlagspad /  
\* Patio Pads

Min. 7,1 lfm/rm



+€

\* Imprägniert Kantholz /  
\* Impregnated beam

40\*60\*1714 mm  
4 Stck/Pcs

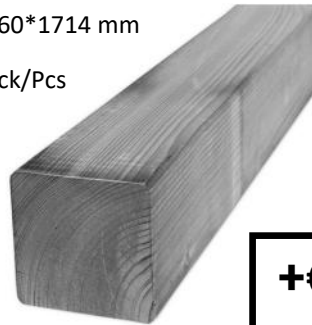

+€

\* Schraube /  
\* Screw

4,5\*70 mm  
20 Stck/Pcs



+€

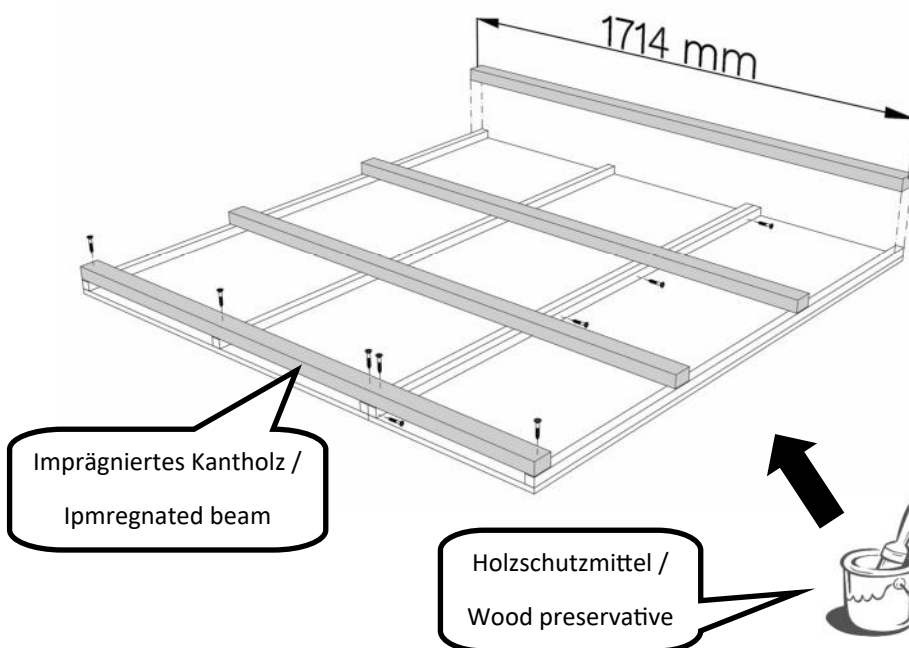
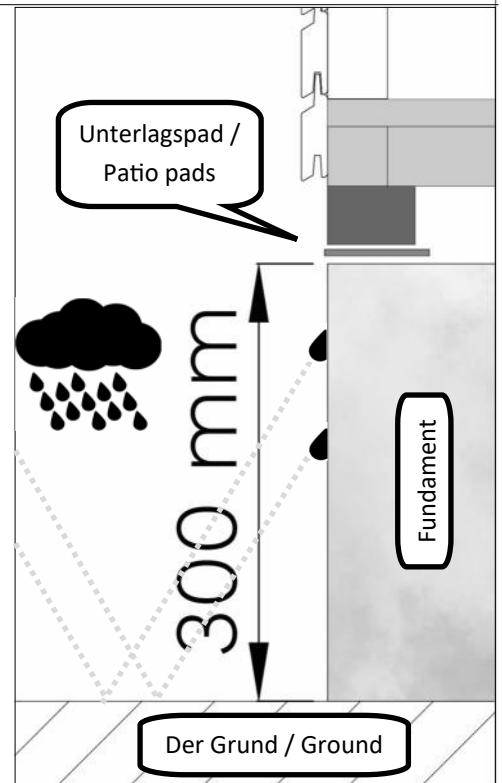

**Bitte beachten!**

Lass Dein Bauvorhaben vorab bei Deiner zuständigen Gemeinde prüfen, denn die Bauordnungen sowie die Bebauungspläne müssen eingehalten werden.

**Please note!**

Have your construction project checked in advance at your responsible municipality, because the building regulations and the development plans must be observed.

# WC201060

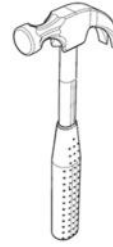
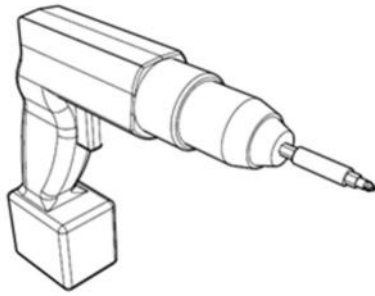

Ø 4 mm

Ø 8 mm



1.

50 mm x 6 St



4 mm



922

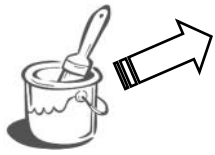

Holzschutzmittel /  
Wood preservative



2.

35 mm x 18 St



922



Holzschutzmittel / Wood preservative

2.1

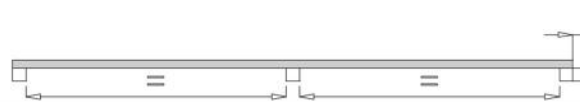

28 mm

3.

35 mm x 12 St



919



922

4.

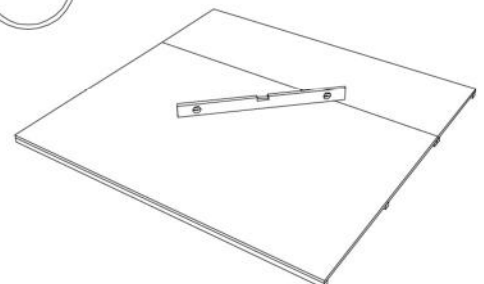

# WC201060

5.

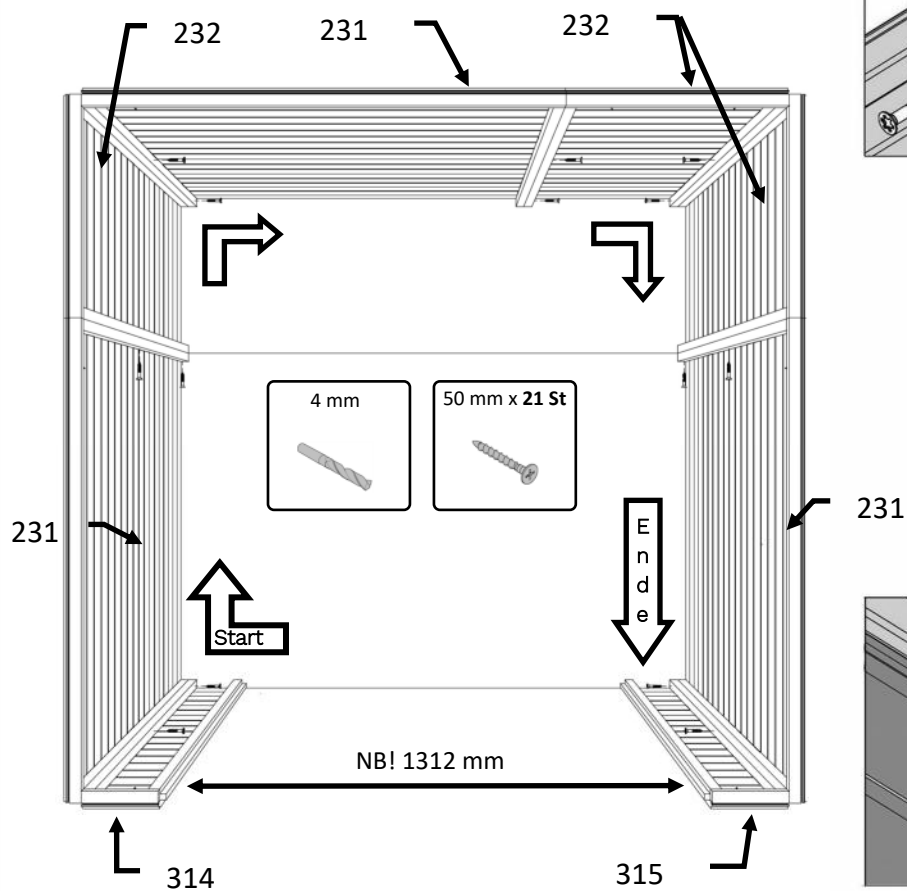

3x

6.

4x

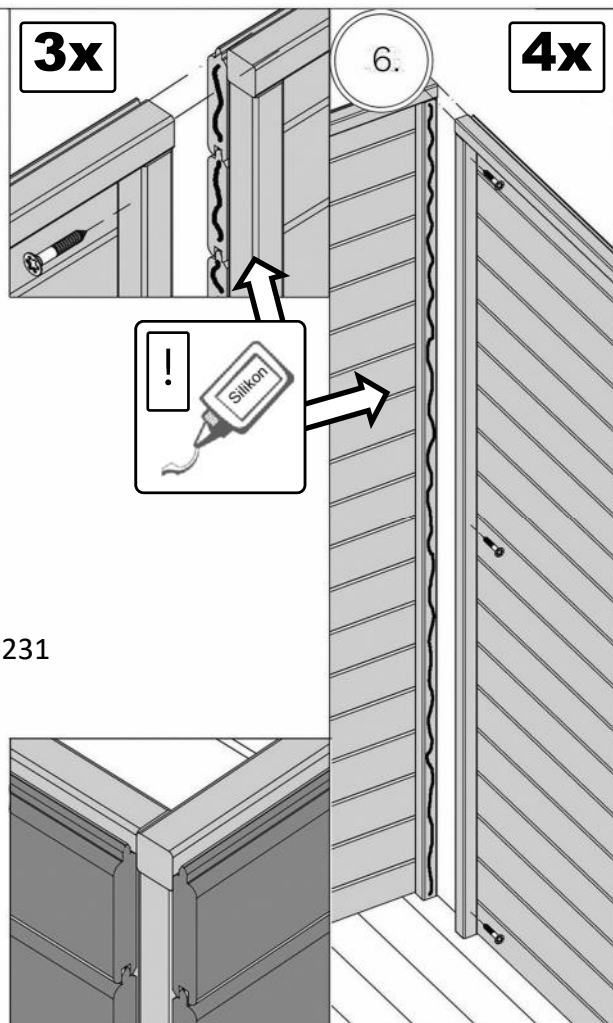

7.

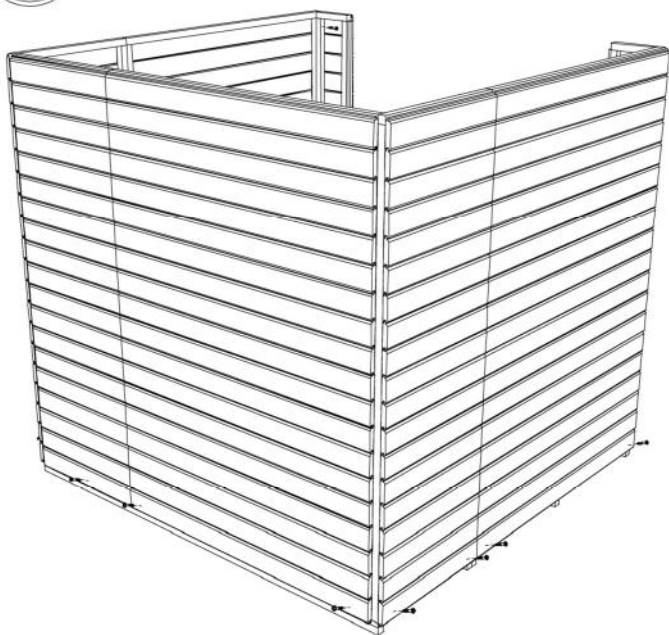

8.

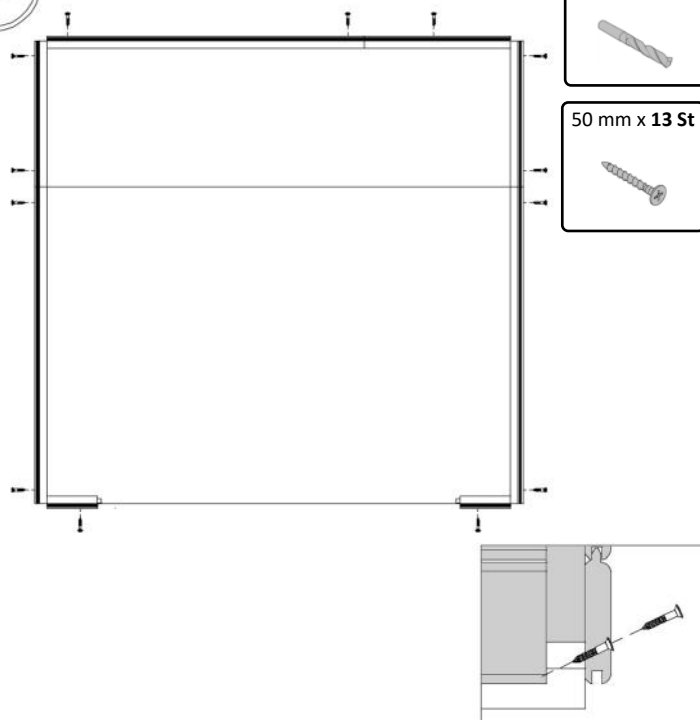

# WC201060

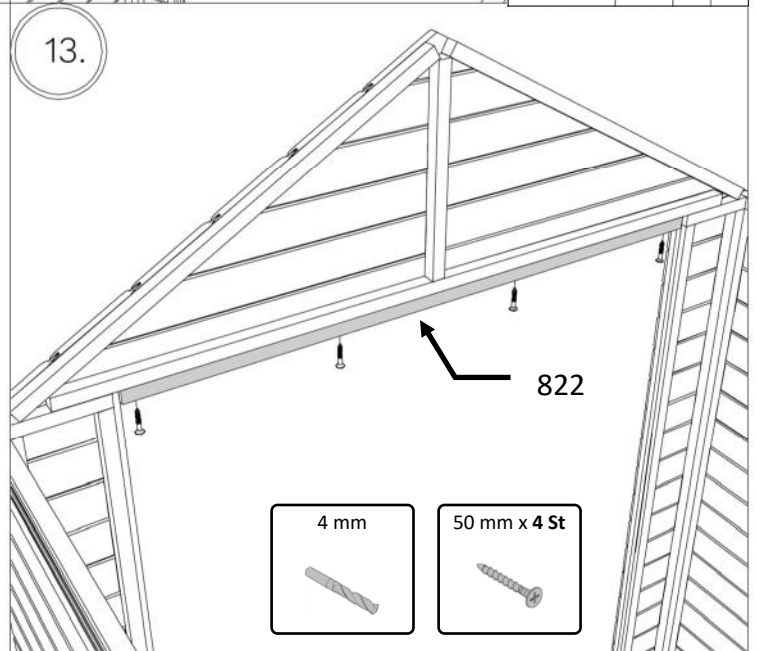
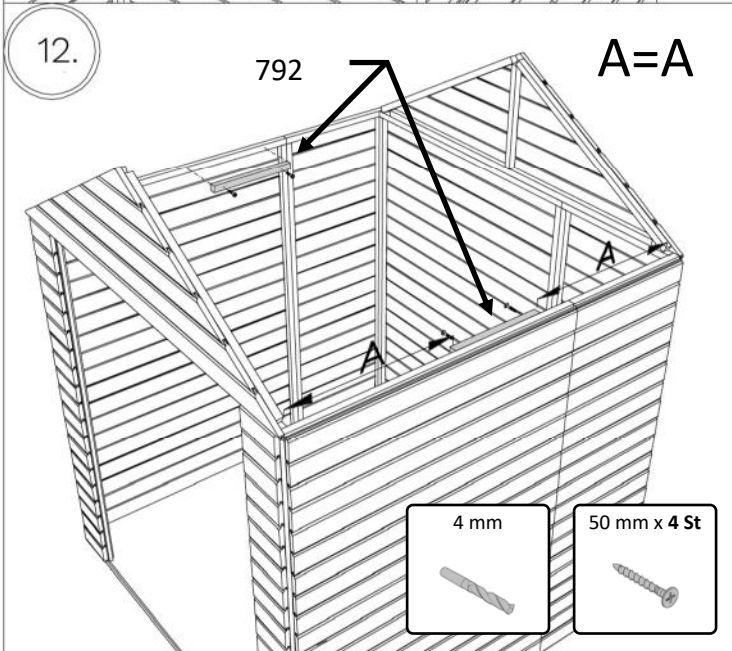
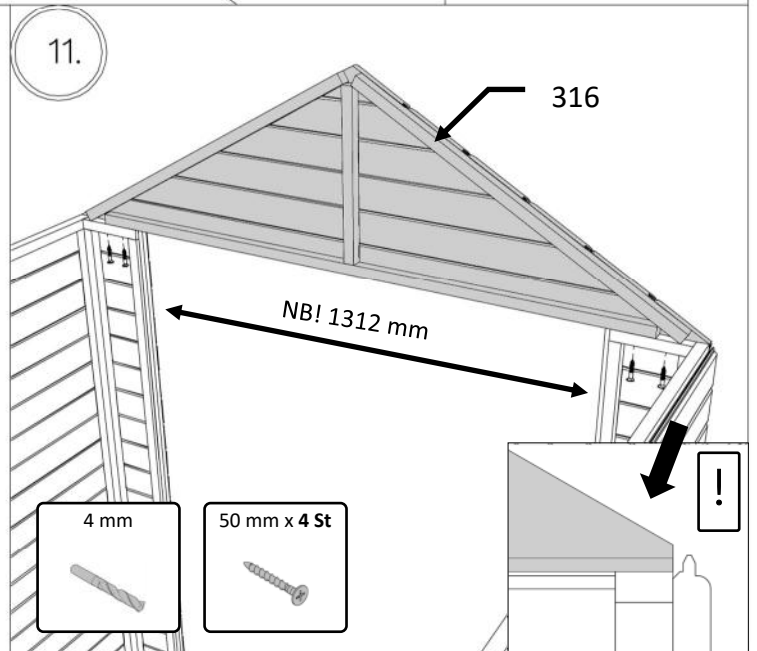
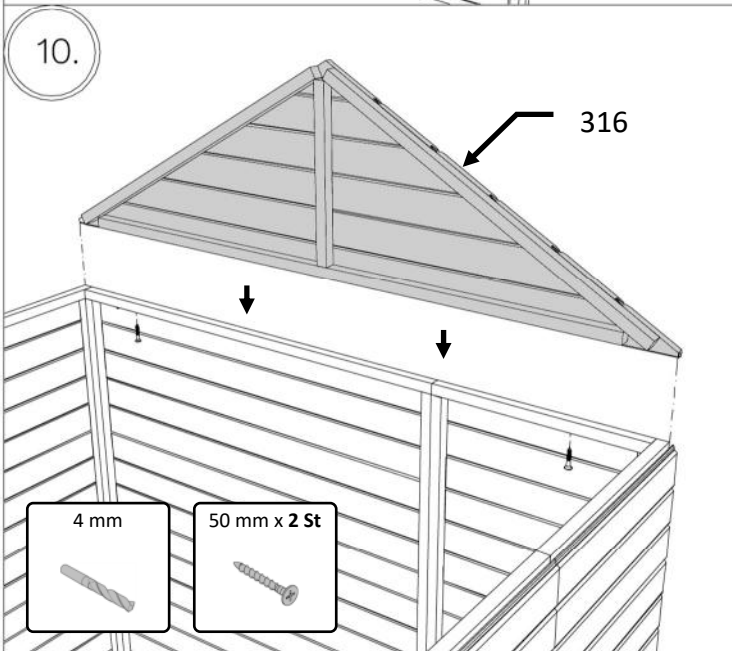
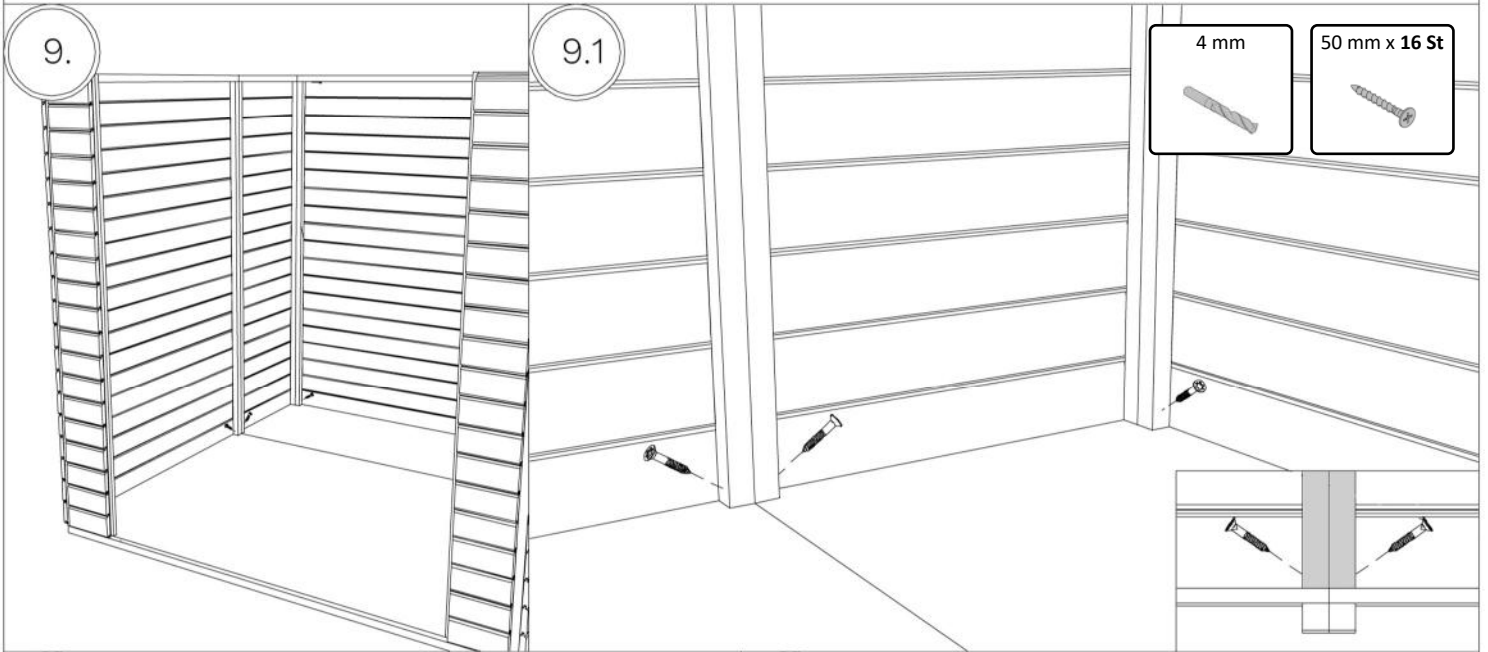

# WC201060

14. NB!

35 mm x 8 St 2x

679

807

15.

516

807

35 mm x 4 St 2x

16.

516

807

35 mm x 4 St 2x

17.

4 mm

50 mm x 4 St 2x

18.

35 mm x 10 St 2x

803

19.

8



# WC201060

19.1

A=B

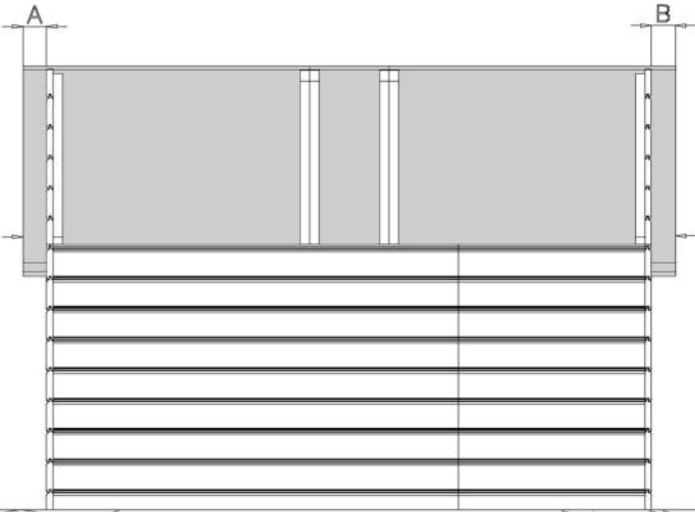

20.

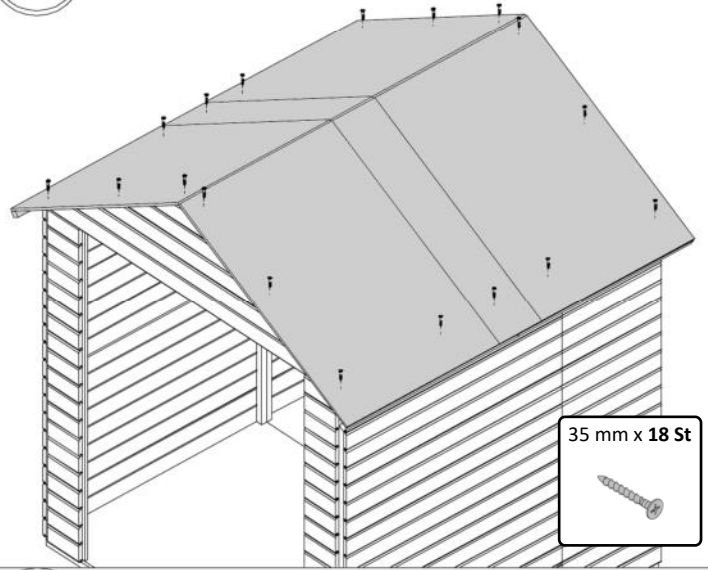

21.

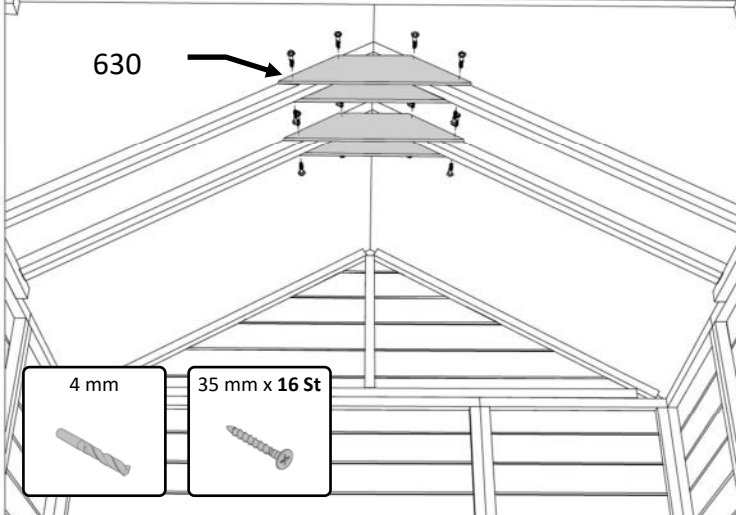

22.

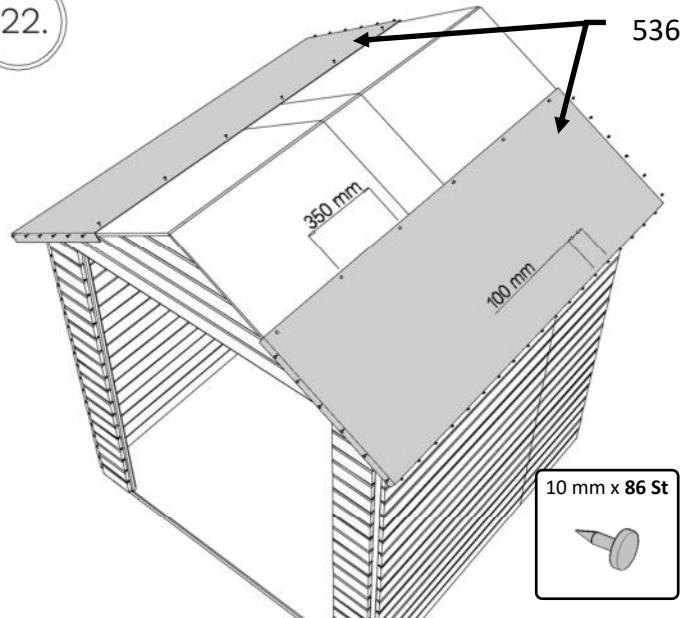

23.

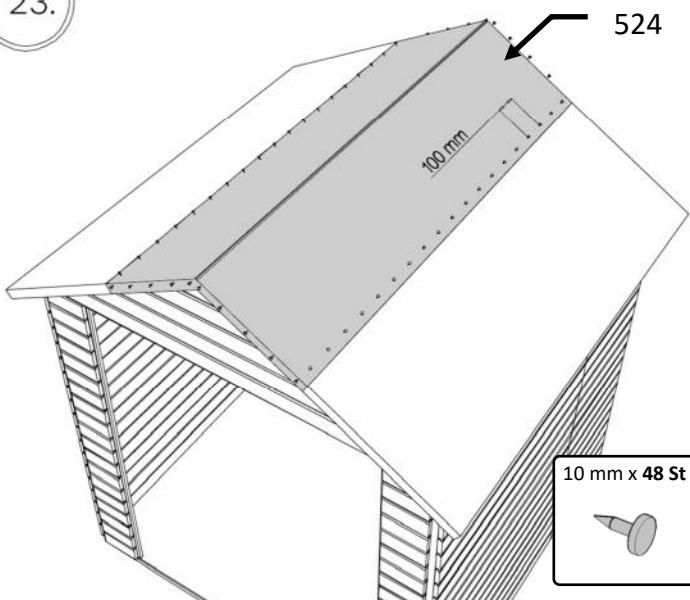

24.

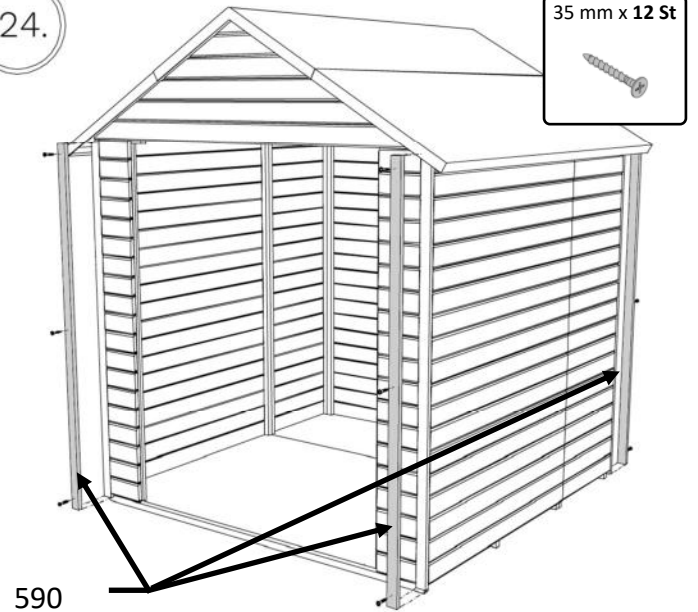

# WC201060

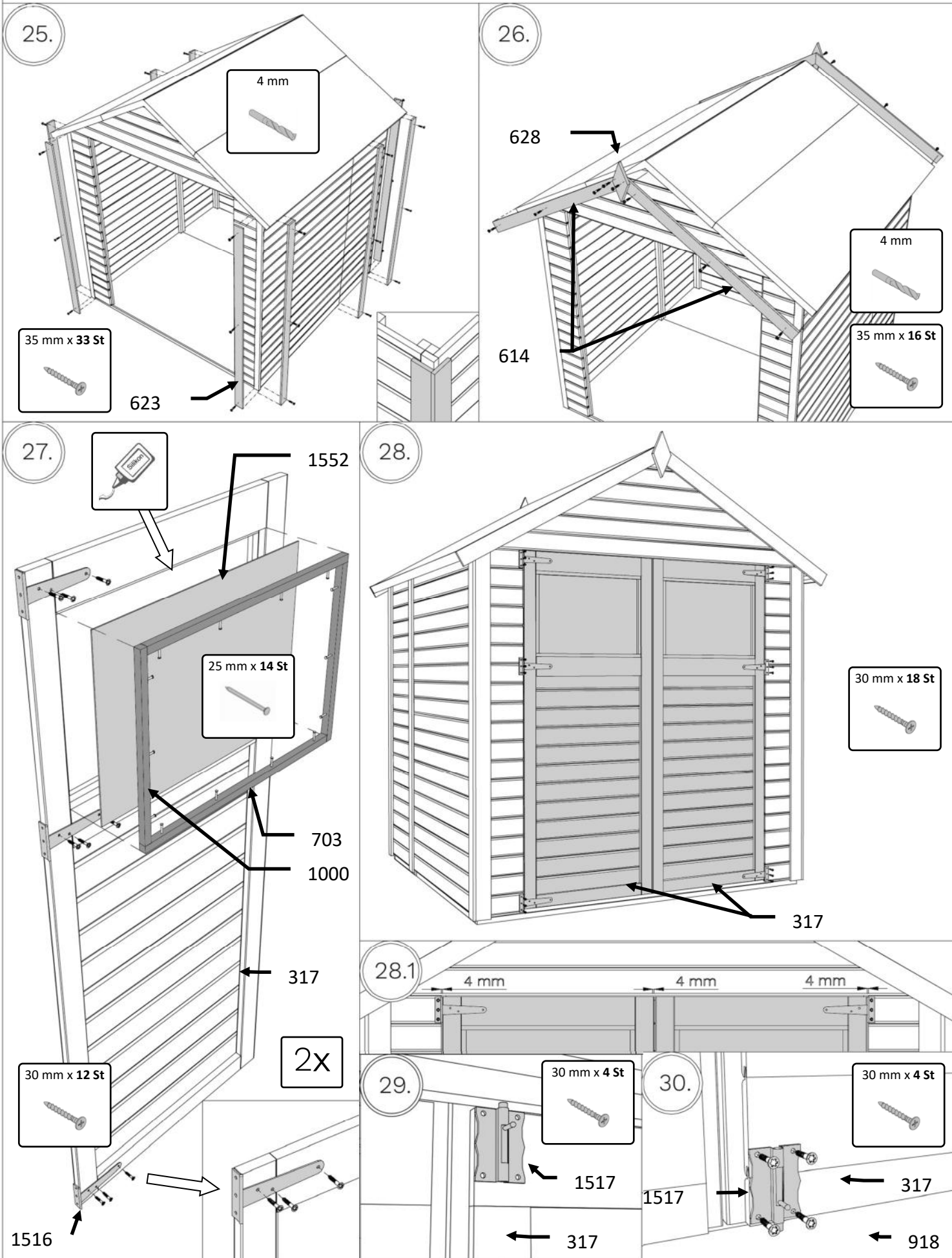

# WC201060

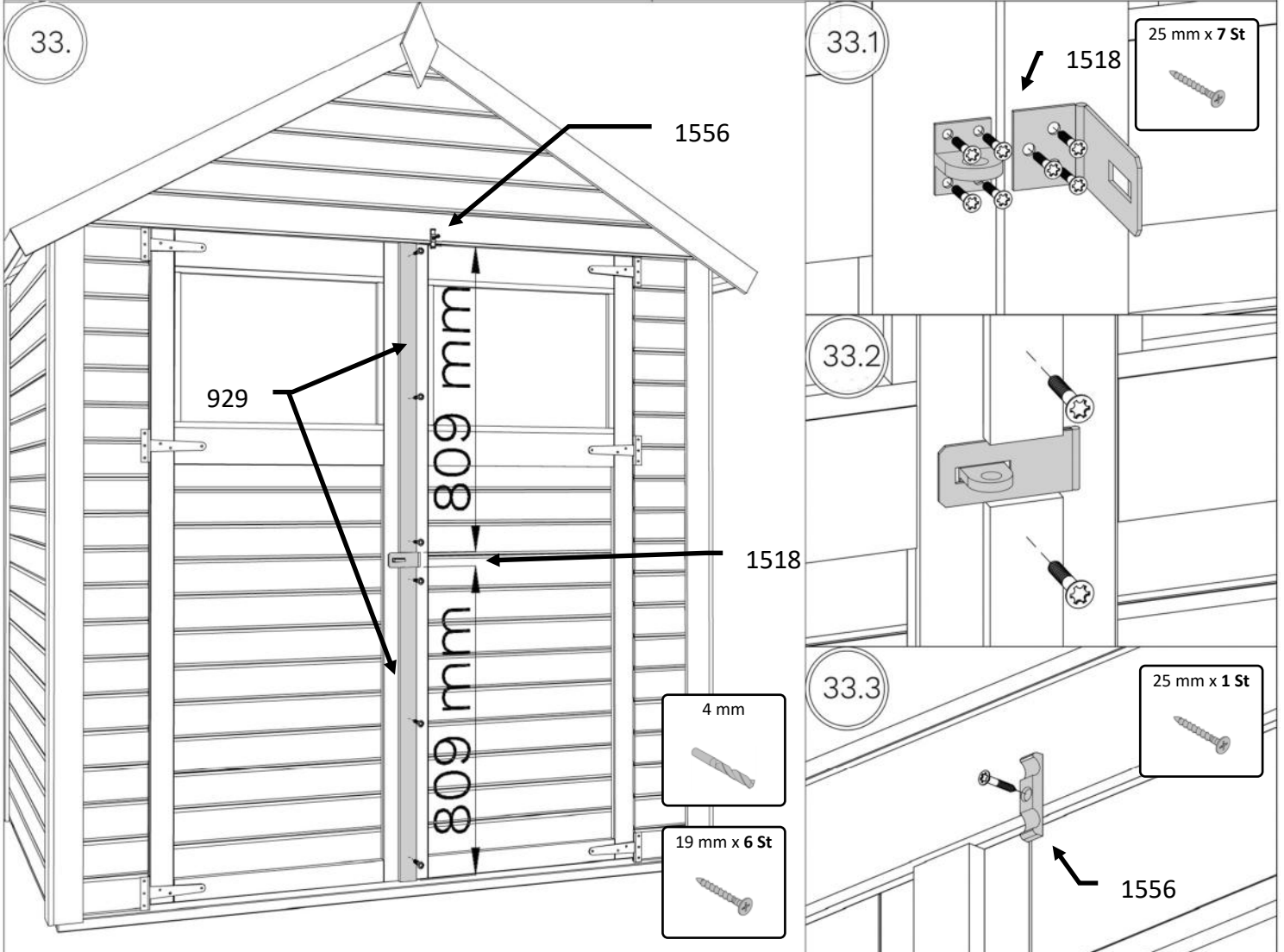
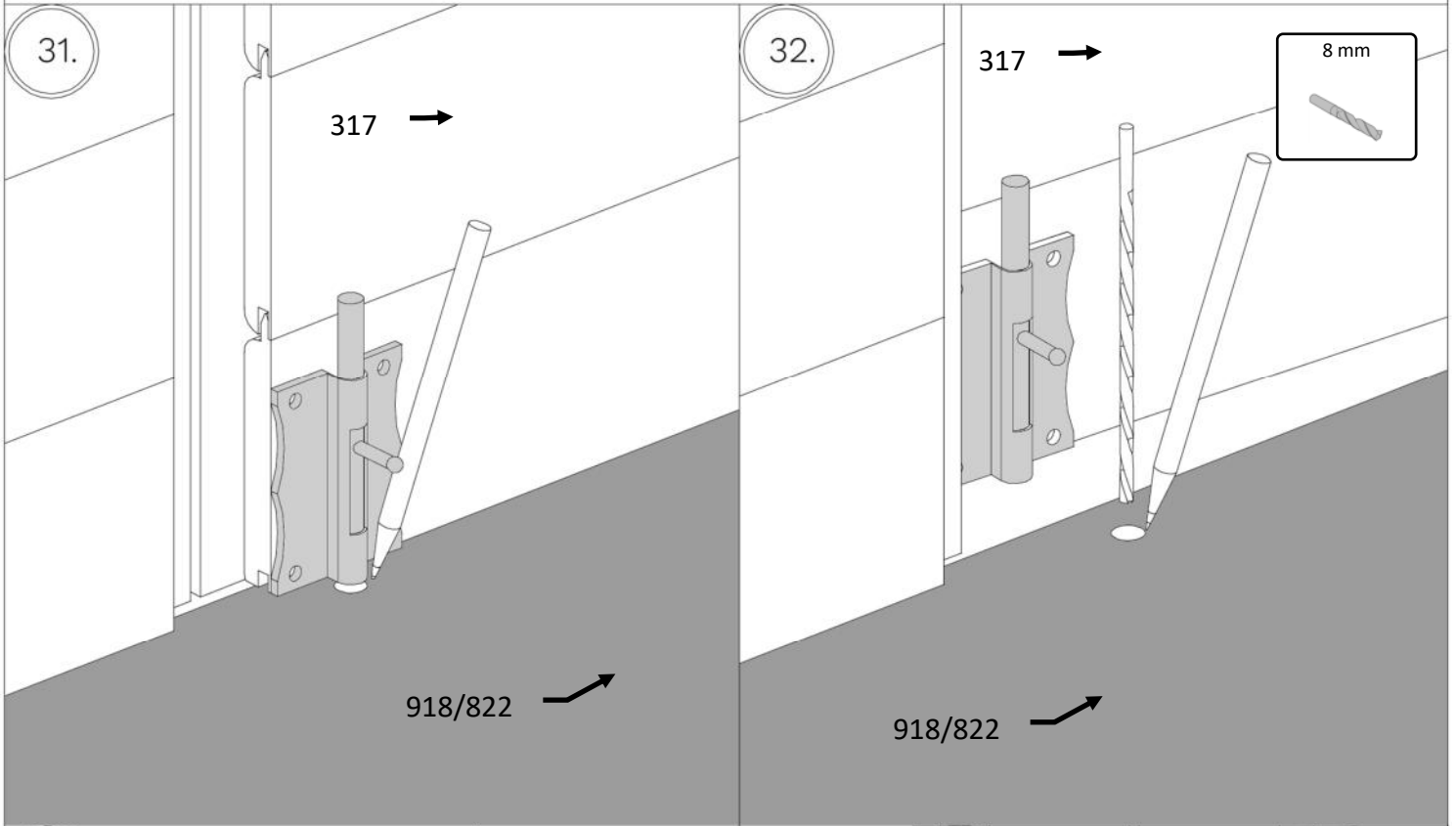

# WC201060

34.

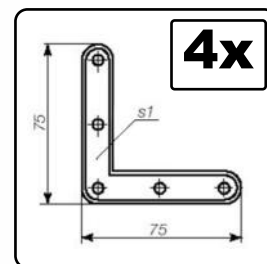
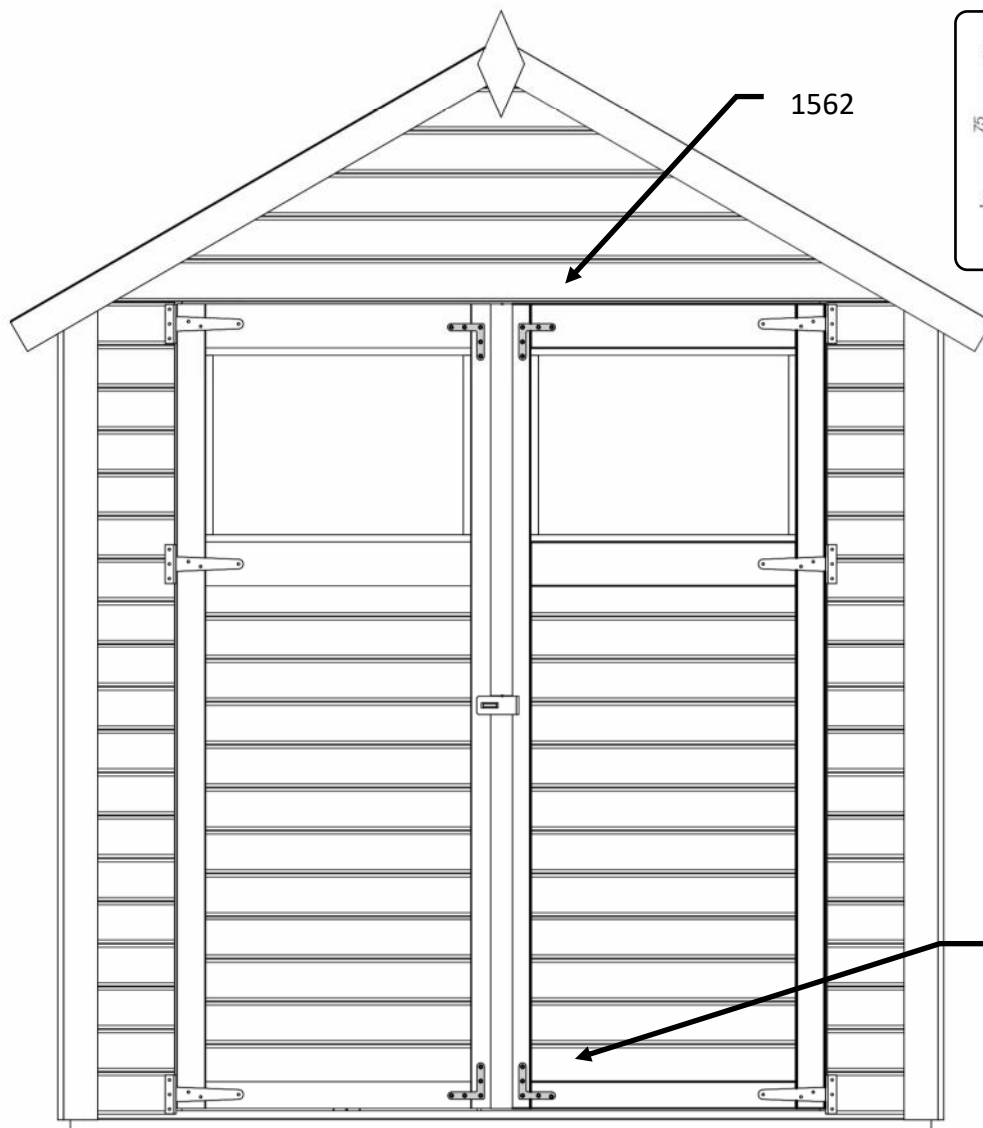

25 mm x 20 St



34.1

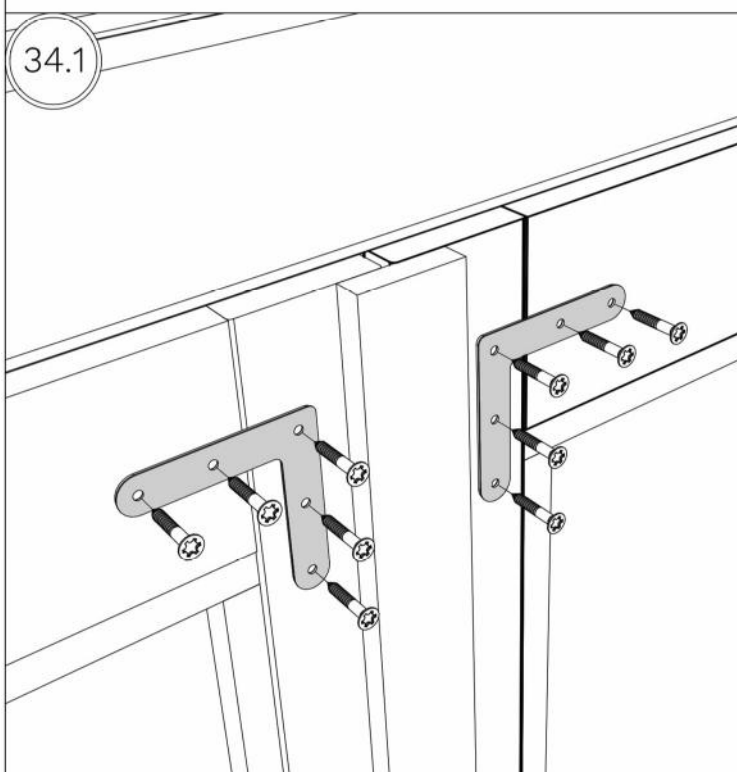

34.2

